



FEATURES:

- Wall mounted
- Non-aerated, yellow plastic spray outlet, dust cap and an automatic flow control
- $\frac{3}{8}$ in. NPT female brass, chrome-plated.
- Brass, chrome-plated squeeze handle activator
- 12 ft. recoiling hose
- Brass chrome-plated flange
- $\frac{3}{8}$ in. NPT female inlet, swivel connection
- 2.12 gpm @ 30 psi
- Universal Emergency Sign Included

COMPLIANCE:

- All units meet existing ANSI/ISEA Z358.1 standards and OSHA rules for drench hoses

OPTIONS:

ADD SUFFIX TO MODEL #

- Vacuum breaker

□ -VB

WARRANTY:

- 3 year limited

SEE REVERSE FOR ROUGH-IN DIMENSIONS

THIS SPACE FOR ARCHITECT/ENGINEER APPROVAL.

SPEAKMAN®

400 ANCHOR MILL ROAD | NEW CASTLE, DE 19720
P: 800-537-2107 | F: 800-977-2747
WWW.SPEAKMANCOMPANY.COM

REVISION DATE: JANUARY 2015



Management Systems
Registered to ISO 9001

SPEAKMAN®

Drench hose SE-925

SPECIFICATION

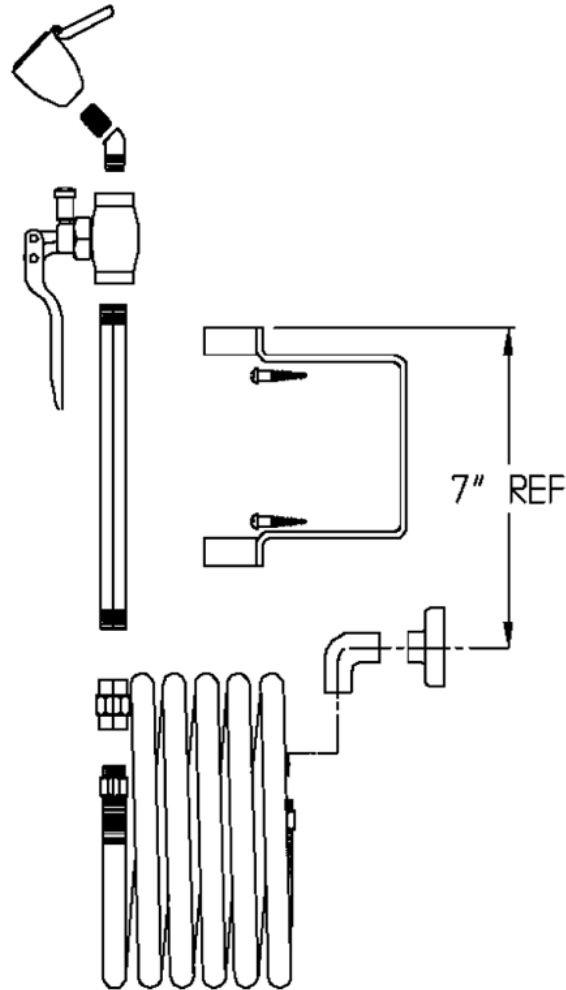

NOTE: 1. All dimensions are in inches (millimeters) unless otherwise specified and are subject to change without notice.

THIS SPACE FOR ARCHITECT/ENGINEER APPROVAL.

SPEAKMAN®

400 ANCHOR MILL ROAD | NEW CASTLE, DE 19720
P: 800-537-2107 | F: 800-977-2747
WWW.SPEAKMANCOMPANY.COM

REVISION DATE: JANUARY 2015



Management Systems
Registered to ISO 9001